

These drawings relate only to Glass Vice® Clearline and its fixings. All other elements are shown indicative only.

© 2021. The copyright of this document is the property of Glass Vice Limited and shall not be reproduced, copied, loaned or disposed of directly, or indirectly, nor used for any purpose other than that for which it is specifically furnished without prior consent.

gv\_clearline.rvt  
All dimensions in millimetres

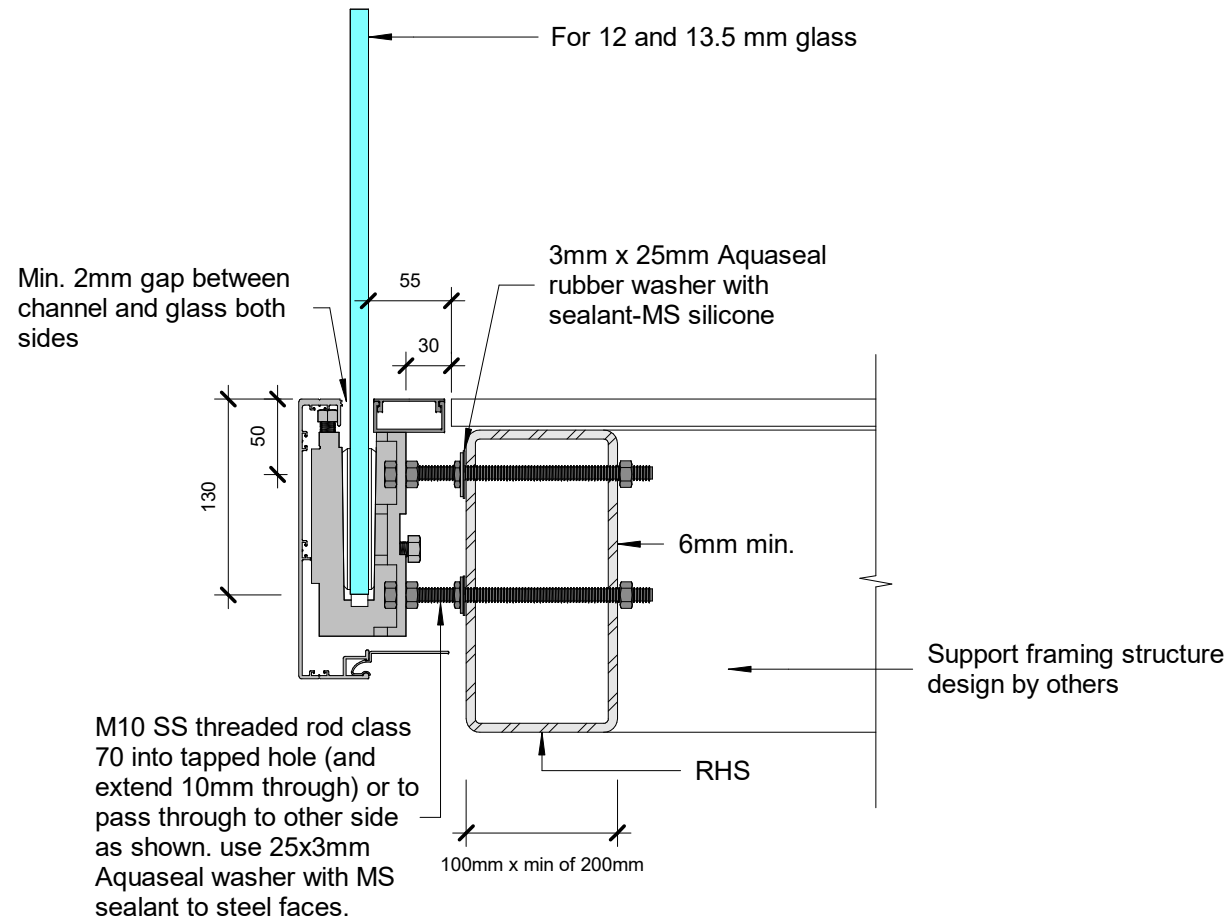

Steel members to be designed by Engineer CPEng.  
Spacing limited by glass capacity - refer to PS1 certificates

These drawings relate only to Glass Vice® Clearline and its fixings. All other elements are shown indicative only.

© 2021. The copyright of this document is the property of Glass Vice Limited and shall not be reproduced, copied, loaned or disposed of directly, or indirectly, nor used for any purpose other than that for which it is specifically furnished without prior consent.

gv\_clearline.rvt  
All dimensions in millimetres

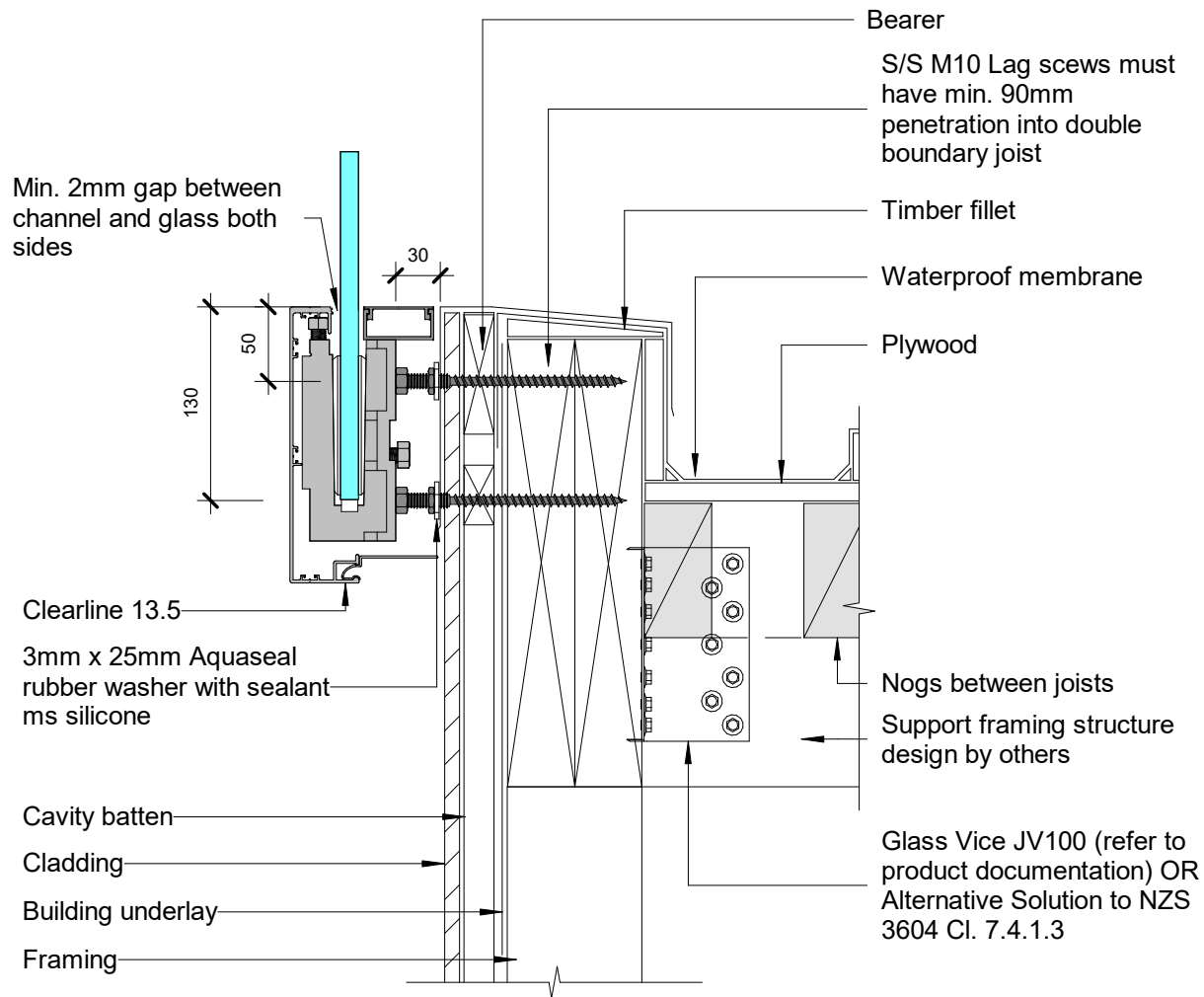

These drawings relate only to Glass Vice® Clearline and its fixings. All other elements are shown indicative only.

© 2021. The copyright of this document is the property of Glass Vice Limited and shall not be reproduced, copied, loaned or disposed of directly, or indirectly, nor used for any purpose other than that for which it is specifically furnished without prior consent.

gv\_clearline.rvt  
All dimensions in millimetres

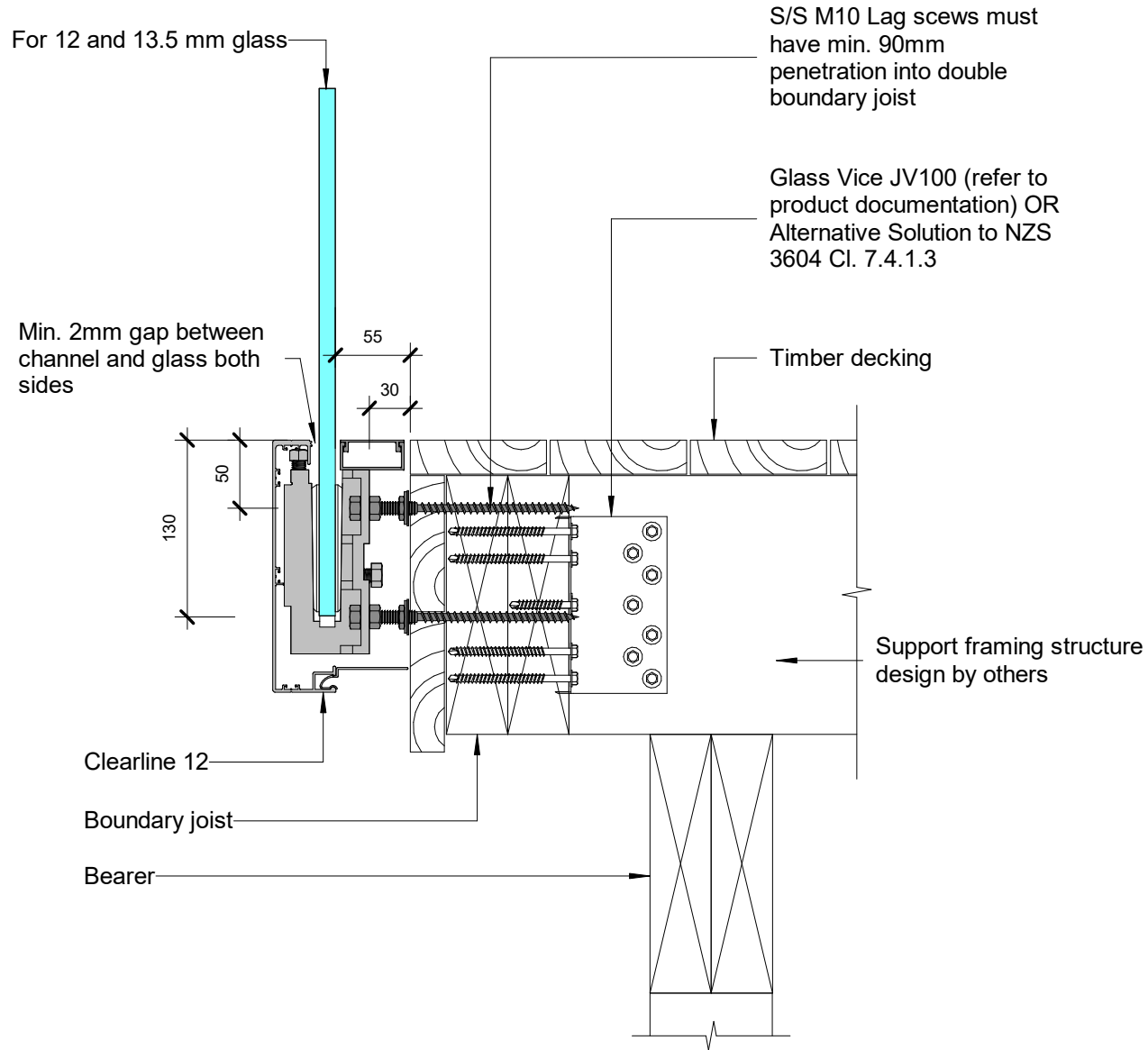

These drawings relate only to Glass Vice® Clearline and its fixings. All other elements are shown indicative only.

© 2021. The copyright of this document is the property of Glass Vice Limited and shall not be reproduced, copied, loaned or disposed of directly, or indirectly, nor used for any purpose other than that for which it is specifically furnished without prior consent.

gv\_clearline.rvt  
All dimensions in millimetres

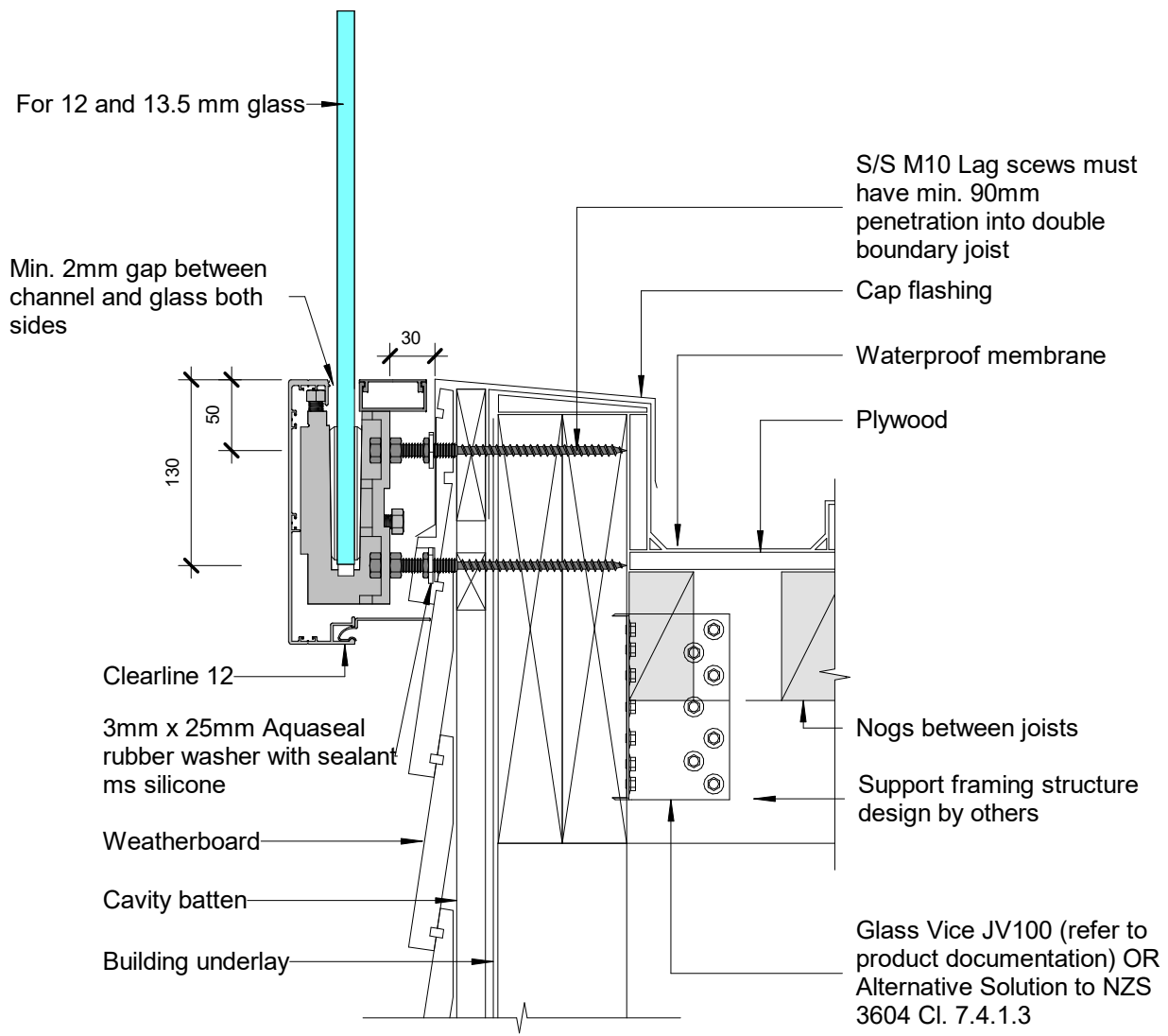

These drawings relate only to Glass Vice® Clearline and its fixings. All other elements are shown indicative only.

© 2021. The copyright of this document is the property of Glass Vice Limited and shall not be reproduced, copied, loaned or disposed of directly, or indirectly, nor used for any purpose other than that for which it is specifically furnished without prior consent.

gv\_clearline.rvt  
All dimensions in millimetres

**GLASS VICE®**  
**Glass Vice® Clearline**  
 Glass Vice® Clearline  
 Deck edge on Weatherboard clad wall

**Sullivan Hall**  
 CHARTERED ENGINEERS

PRODUCER STATEMENT  
 DESIGN  DESIGN REVIEW

REVIEWED FOR SPECIFICALLY DESIGNED  
 STRUCTURAL CONTENT ONLY AS DESCRIBED  
 IN CALCULATIONS ONLY

**CLP ENG**

Date: Sep 2021  
 Scale: 1 : 5  
 1.0

www.glassvice.com  
 Phone +64 9 414 6565  
 info@glassvice.com

Quick Code:

**GV\_4CL\_DET\_WBD01**